

Towards 4G

Robert Bestak



Czech Technical University in Prague
Faculty of Electrical Engineering



Czech Technical University in Prague
Faculty of Electrical Engineering
Department of Telecommunication Engineering

- Evolution of UMTS
- LTE
- WiMAX
- UMTS vs. LTE vs. WiMAX

Generation of mobile networks

Generation	Name	Features
1 (1980)	NMT (<i>Nordic Mobile Telephone</i>), ...	Analog Voice
2 (1992)	GSM (<i>Global System for Mobile communications</i>) - GSM 900, GSM 1800 IS95 (<i>Interim Standard</i>) based on CDMA - IS95a,b ...cdmaOne	Digital Voice + data
2,5 (1999)	GPRS (<i>General Packet Radio Service</i>) EGPRS/EDGE (<i>Enhanced GPRS/Enhanced Data rates for Global Evolution</i>)	
3 (2004)	UMTS (<i>Universal Mobile Telecommunication System</i>) cdma2000 (<i>code division multiple access</i>)	Multimedia
... 4		

Releases in 3GPP

- **Release 99** (1999)
 - 1st release
- **Release 4** (2001)
- **Release 5** (2002)
 - HSDPA (*High Speed Downlink Packet Access*)
 - IMS (*IP Multimedia Subsystem*)
- **Release 6** (2004)
 - MBMS (*Multimedia Broadcast/Multicast Services*)
 - HSUPA (*High Speed Uplink Packet Access*)
- **Release 7** (2007)
 - HSPA+
- **Release 8** (2009?)
 - ...LTE (*Long Term Evolution*)

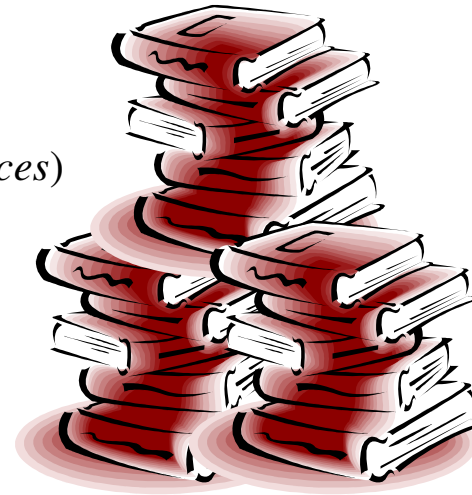

3GPP, 3GPP2

- 3GPP

- Created 1998
- Specification of UMTS
- www.3gpp.org



- 3GPP2

- Specification of cdma2000
- www.3gpp2.org



CN evolutions

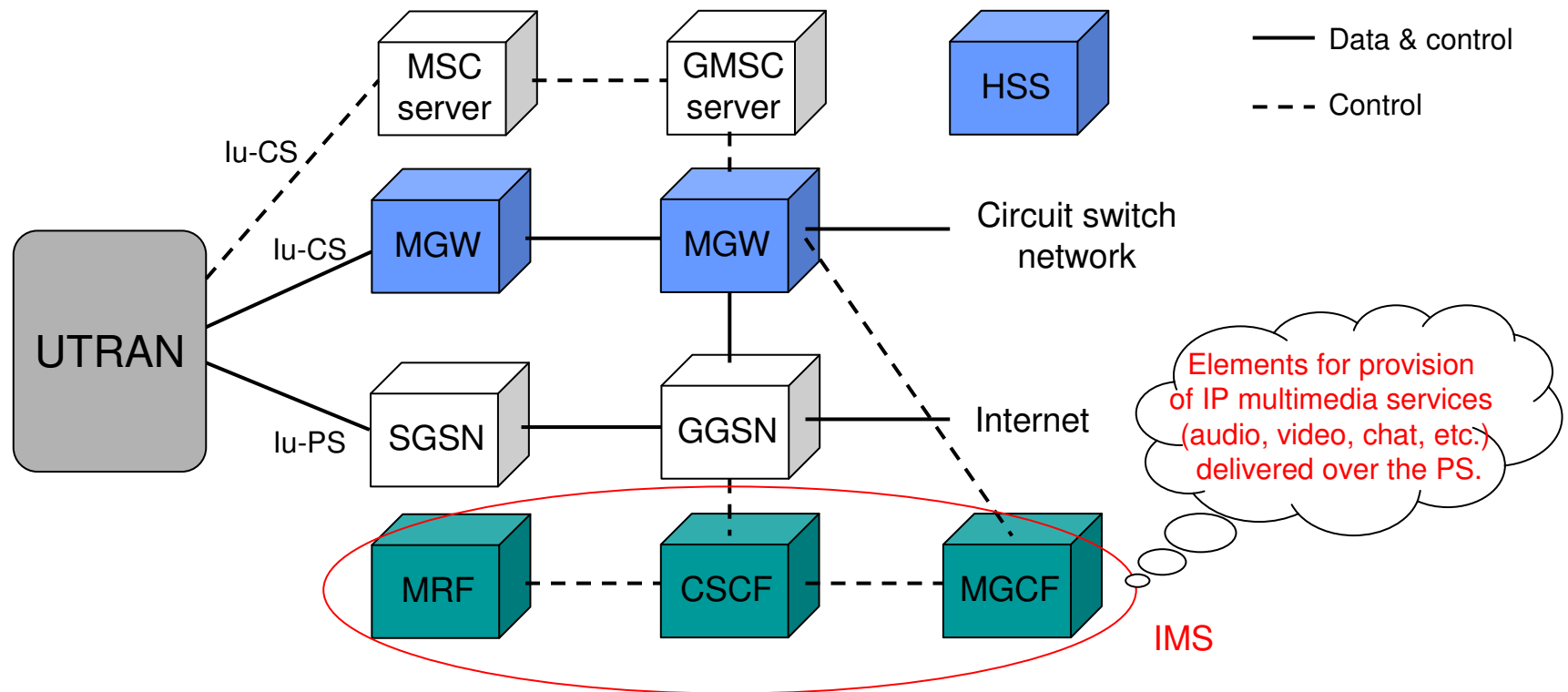

MGM: Media Gateway
HSS: Home Subscriber Server
IMS: IP Multimedia Subsystem

MRF: Media Resource Function
CSCF: Call Session Control Function
MGCF: Media Gateway Control Function

MBMS ... *Multimedia Broadcast/Multicast Service*

- Release 6 (2004)

Aim: increase of transmission efficiency for multimedia services

- Point-to-multipoint
- Applications
 - Mobile TV (...DVB-H)
 - Audio/ video (news, weather, etc.)
 - Specific information (about hotels, restaurants, etc.)

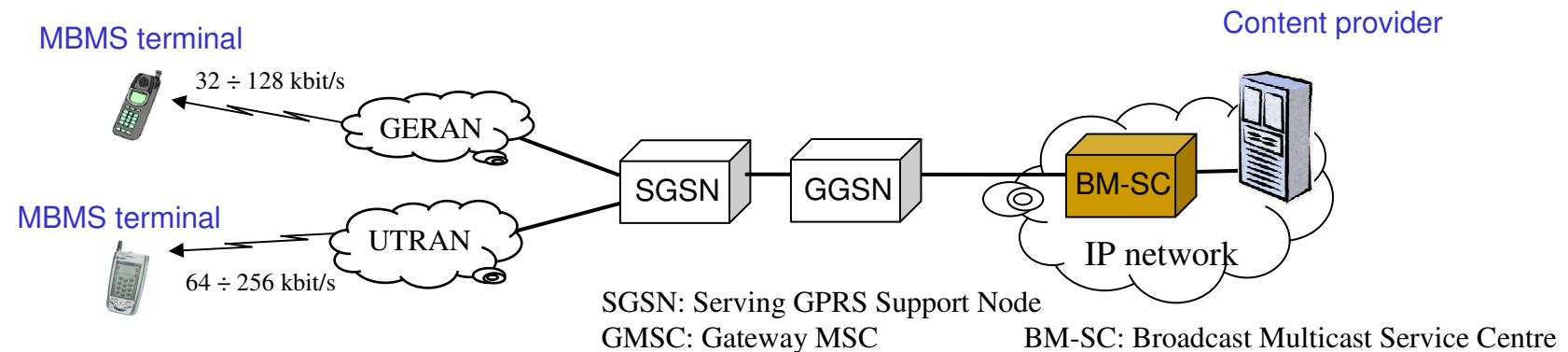

What is HSPA?

- **HSDPA** (High Speed Downlink Packet Access)

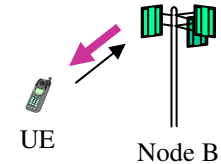

- **HSUPA** (High Speed Uplink Packet Access)
 - E-DCH (Enhanced Uplink Dedicated Channel)

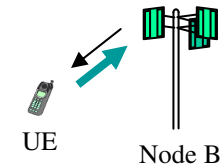

3GPP 1st version
of specification

R5 HSDPA

R6 HSUPA

2002

2003

2004

2005

2006

2007

2008

Commercial
networks

HSDPA

HSUPA

Basic features

- Companies involved in the initial studies
 - Motorola, Nokia, Ericsson, T-Mobile, NTT DoCoMo, ...
- Deployed of HSPA in the WCDMA network
 - Same carrier
 - Another carrier
- HSPA requires
 - Modification of Node B and RNC
 - HSPA terminals

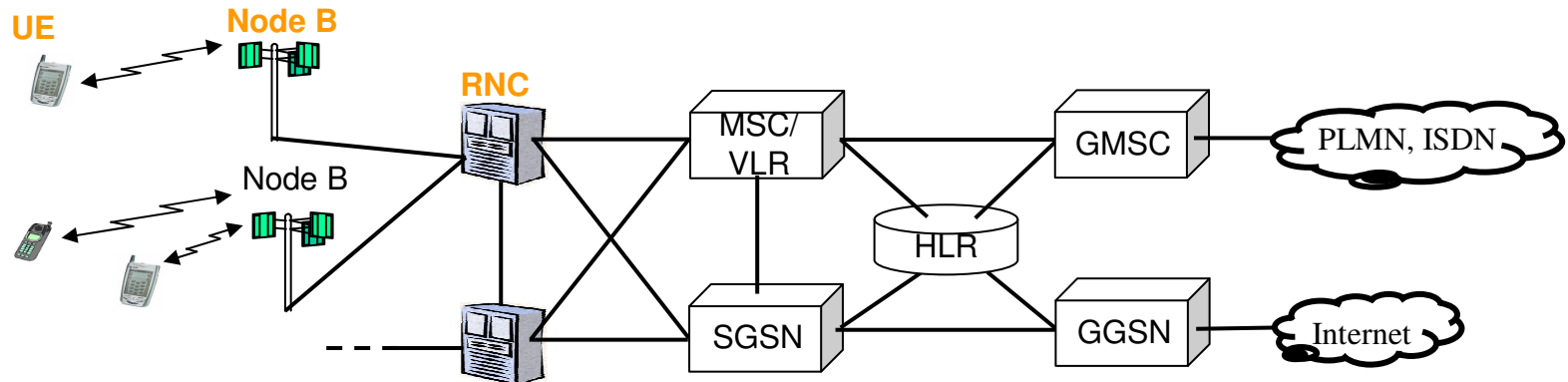

Modifications

- Scheduling
- Fast Retransmission (HARQ_{MAC})
- Adaptive Modulation and Coding

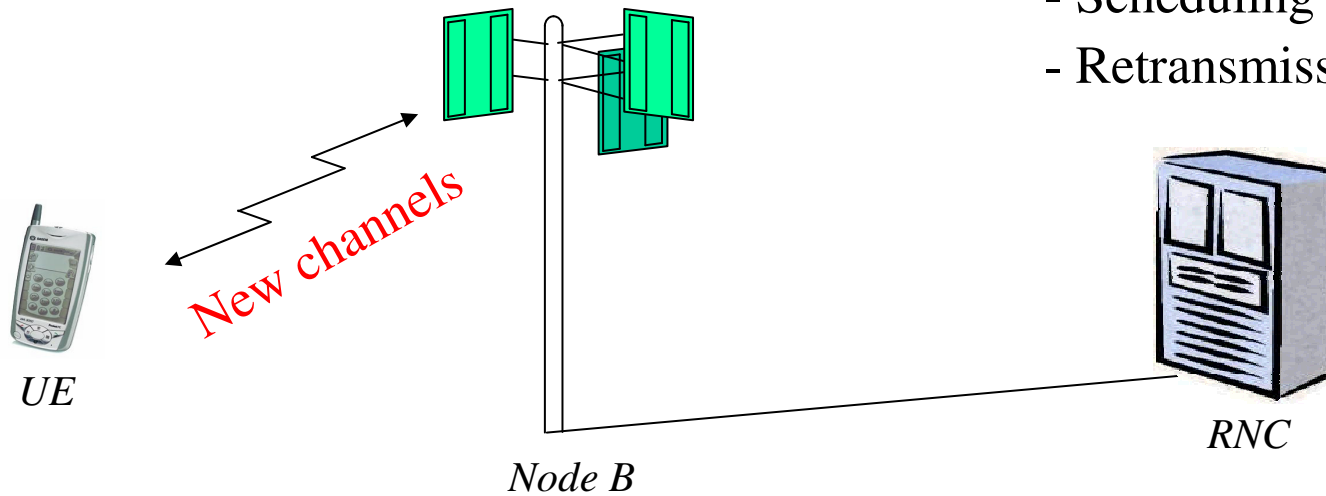

- Scheduling
- Retransmission (ARQ_{RLC})



Commercial HSDPA networks

220 HSDPA network commitments in 92 countries

185 commercial HSDPA operators in 80 countries/territories



www.gsacom.com

 Countries with commercial 3G/HSDPA operators
 Countries with 3G/HSDPA network commitments/deployments

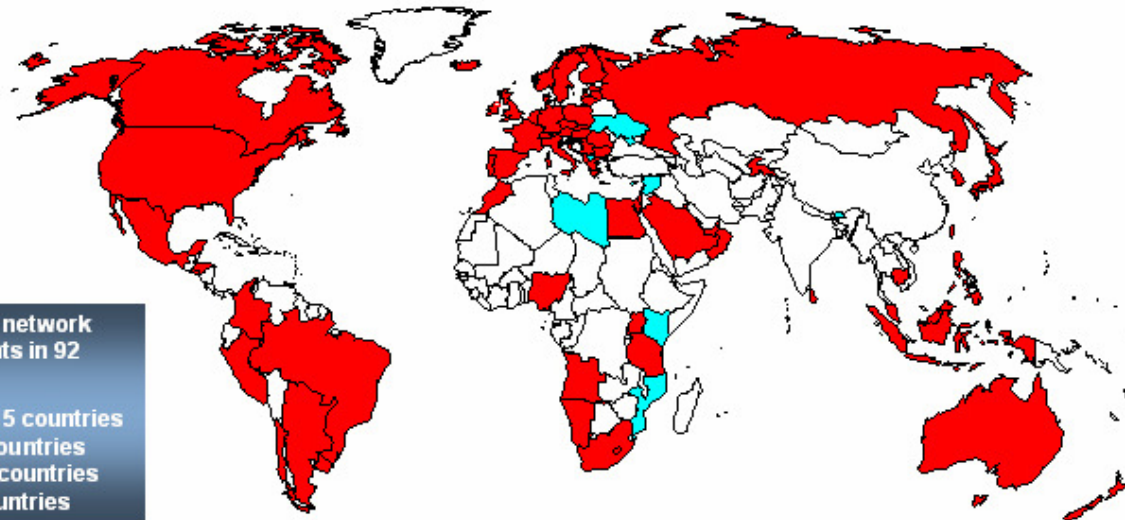

220 HSDPA network commitments in 92 countries
Americas: 15 countries
APAC: 16 countries
Europe: 42 countries
MEA: 19 countries

(c) GSA – Global mobile Suppliers Association: March 7, 2008

Statistics

Fast Facts – March 10, 2008

Over 1.1 billion GSM, WCDMA and HSPA subs in commercial HSPA-enabled networks globally



The GSM technology family embraces GPRS, EDGE, WCDMA-HSPA – all open 3GPP standards

2.844 billion GSM, WCDMA subs Q4 07
586 million subscriptions added in 2007

GSM, WCDMA has 86.6% market share Q4 07
(2.7% gain in market share in 2007)

179 million WCDMA subs including HSPA end 2007

Over 75% of 450+ commercial GPRS operators
globally committed to EDGE

345 GSM/EDGE network commitments in 158
countries; 290 network launches, 136 countries

700+ GSM/EDGE devices launched (October 2007)

Most WCDMA-HSPA networks combine with EDGE
for service continuity, best user experience

211 3G/WCDMA operators launched in 91 countries
= 72% share of 293 commercial 3G networks

800+ WCDMA user devices launched, 90+ suppliers

220 HSDPA network commitments in 92 countries,
including 185 commercial launches in 80 countries
103 HSDPA networks launched in Europe

87.6% i.e. 7 out of 8 live WCDMA operators also
launched HSDPA

403 devices launched by 80 suppliers (Oct 2007)
• 75 devices support tri-band 850/1900/2100

116 HSDPA operators launched 3.6 Mbps (peak) or
higher in 58 countries = 62.7% of live HSDPA
operators. 147 HSDPA devices support 3.6 Mbps

38 operators launched 7.2 Mbps (peak); 63 devices

34 HSUPA network launches; 24 more HSUPA
network commitments; 33 HSUPA devices launched

Network deployments, devices data source: GSA surveys
Mobile subscribers data source: Informa Telecoms & Media

www.gsacom.com

Global mobile Suppliers Association © 2008

HSDPA vs. HSUPA

	H S D P A	H S U P A
Introduced	Release 5	Release 6
Improve data rates	Downlink	Uplink
Peak data rate	14,4 Mbit/s	5,8 Mbit/s
Transport channel	Shared (HS-DSCH)	Dedicated (E-DCH)
	TTI = 2 ms	TTI = 2 ms, 10 ms
Features	HARQ	HARQ
	Scheduling	Scheduling
	Adaptive modulation and coding	-
Spreading factor	Fix (=16)	Variable
Modification	UE, Node B	UE, Node B, RNC
New MAC entities	MAC-hs	MAC-e, MAC-es

- 3G LTE (Long Term Evolution)
 - UTRAN LTE, Evolved UTRAN
 - 3GPP 25.913, 3GPP 25.813
- **Why**
 - HSPA ...should be competitive for several years
 - **But**, to ensure competitiveness in an longer time (beyond 2015), a long-term evolution of the radio-access technique needs to be considered (... rates, latency, coverage, operator's cost, etc.)

Features of LTE (1/4)

- Scalable bandwidth



- Peak data rates

- Downlink: 100Mbit/s (within 20 MHz)
 - Uplink: 50Mbit/s (within 20 MHz)
- } not necessarily simultaneously

- Throughput

- Downlink: 3x or 4x Release 6 (HSDPA)
- Uplink: 2x or 3x Release 6 (HSUPA)

Features of LTE (2/4)

- **No CS, only PS domain**

- Number of transport chs is reduced
- Dedicated chs. → shared chs.

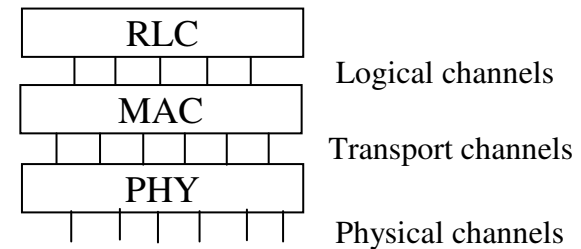

- **Cell range**

- 5 km: optimal size
- 30km: sizes with reasonable performance
- Up to 100km cell sizes supported with acceptable performance

- **Cell Capacity**

- Up to 200 active users per cell (5MHz)

Features of LTE (3/4)

- **Mobility**
 - Optimized for low mobility (0÷15 km/h) but
 - Also support high speed
- **Latency**
 - User-plane: < 5 ms
 - Control plane: < 100 ms (camped-to-active), < 50 ms (dormant-to-active)
- ...
 - Enhanced IMS
 - Enhanced MBMS (Multimedia Broadcast Multicast Service)

Features of LTE (4/4)

- **Radio interface**

- SC-FDMA (Uplink)
- OFDM (Downlink)

...multi-carrier WCDMA is considered to be complicated (especially for UEs)

- **Network architecture**

- User plane ⇒ fewer nodes (two nodes approach)
 - One node - Base station
 - Second node - Other (upper) node, handling CN + some radio functions
- Control plane ⇒ more freedom
 - More intelligence implemented in Base station (...than currently with HSPA)

HSOPAHigh Speed **OFDM** Packet Access

- Provides HS downlink/uplink data channel
 - OFDM (Orthogonal Frequency Division Multiplexing)
 - MIMO (Multiple-Input Multiple-Output)
- Introduce in future Release (...expected in 2008)

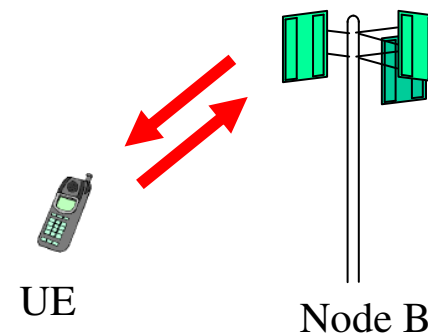

- HSDPA (HS **downlink** packet access)
 - Release 5 (2002)
- HSUPA (HS **uplink** packet access)
 - Release 6 (2004)
- HSOPA (HS **OFDM** packet access)
 - *Future Release*

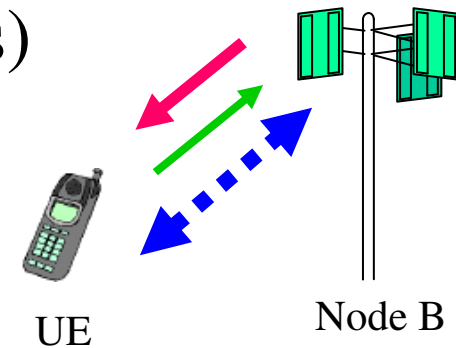

Generation of mobile systems

Generation	Features	Features
3 (2003)	UMTS (<i>Universal Mobile Telecommunication System</i>) cdma2000 (<i>code division multiple access</i>)	Multimedia
3,5 (2005)	HSDPA (<i>High Speed Downlink Packet Access</i>)	High speed data rates
3,75 (2007)	HSUPA (<i>High Speed Uplink Packet Access</i>)	
3,9 (?)	HSOPA (<i>High Speed OFDM Packet Access</i>)	
4?		

IEEE wireless standards

802.11 WG
Wireless Local Area
Network & Mesh

802.11a ... 802.11n

802.15 WG
Wireless Personal Area
Network

802.15.1 ... 802.15.5

802.16 WG
Broadband Wireless
Access

802.16a ... 802.16e

802.20 WG
Mobile Broadband Wireless
Access

802.22 WG
Wireless Regional Area
Network

*IEEE: Institute of Electrical and Electronics Engineers

WiMAX (1/2)

Access networks (last mile)

... metallic cables, optical cables, radio

WiMAX

- a) Substitution of cables
- b) ...Mobile network

WiMAX (2/2)

- **WiMAX** (*Worldwide Interoperability for Microwave Access*)
 - 2001
 - IEEE 802.16
 - BWA
 - Outdoor (...metropolitan access network)
 - Support of QoS

- **WiMAX Forum**
 - Promoting IEEE 802.16
 - Promotion & certification of equipments
 - Specification of tests, selection of labs for certification
 - www.wimaxforum.org



... WiMAX Forum continues, where IEEE ends

Frequency bands

- Unlicensed / licensed spectrum
- 10-66 GHz
 - Line of Sight (LOS)
 - Cell radius - up to 40÷50km
- 2-11 GHz
 - Non Line of Sight (NLOS)
 - Cell radius - up to 7÷9 km
 - ...power management, MIMO

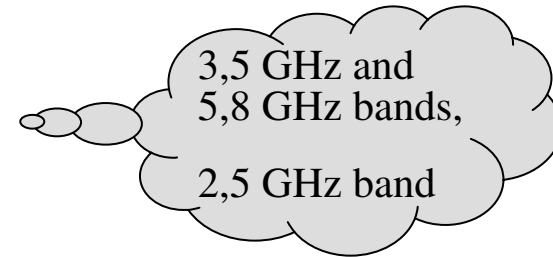

Note: Unlicensed spectrum

+ Free, allows quickly meet the needs of users

- To eliminate interferences, arrangement between providers is needed

IMT-2000

- International Mobile Telecommunications-2000
 - Global standard for 3G wireless communications, defined by ITU
- Approved standards
 - 1999: WCDMA, CDMA2000, TD-SCDMA, EDGE and DECT
 - 9/2007: WiMAX

WiMAX joined IMT-2000

Consequence... access to frequencies that are reserved for 3G technologies by ITU

802.16 versions (1/2)

- 802.16 2001/12
 - LOS (10-66 GHz), up to 135 Mbit/s
- 802.16c 2002
- 802.16a 2003/01
 - NLOS (2-11 GHz), up to 75 Mbit/s
- 802.16REVd (**802.16-2004**) 2004/10
- **802.16e** 2005/12
 - *Mobility*
- **802.16j** 2008/?
 - Relay
- 802.16m 2009?
 - ...Advance WiMAX (1Gbit/s)

802.16 versions (2/2)

- Fixed WiMAX
 - 802.16-2004
- Mobile WiMAX
 - Amendment to 802.16-2004 → 802.16e ...handover
 - WiBro (Wireless Broadband) ...South Korean, 2006
- WiMAX
 - 802.16j ...relay

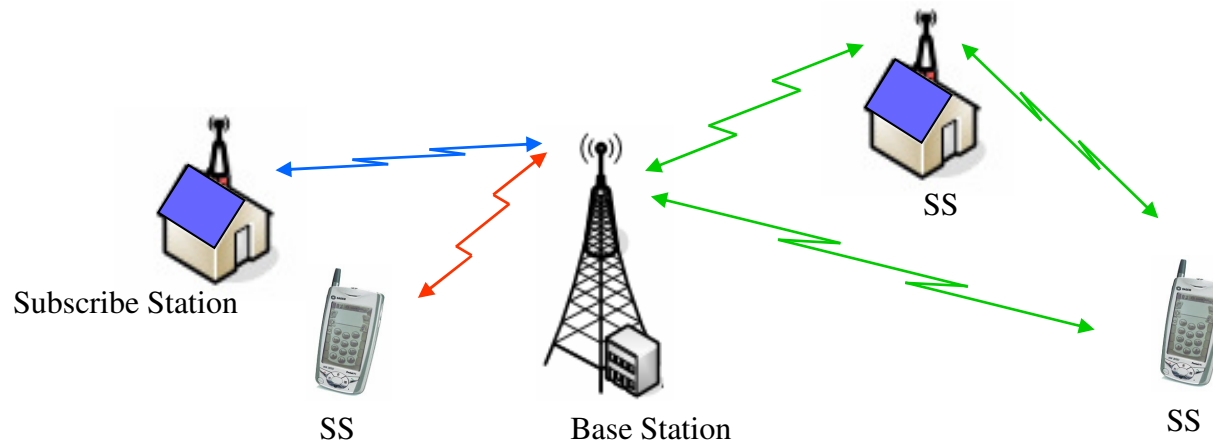

Features

- Flexible channel size
 - 1,75 MHz ÷ 20, 28 MHz (...1,75; 3,5; 5; 7; 10;...)
 - ...increase of cell capacity in the network
- High data rates
 - Over 100 Mbit/s (depends on the channel bandwidth)
- QoS support
 - ..support low latency applications (e.g., voice or video)
- FDD/TDD modes

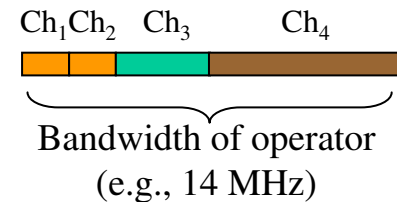

UMTS vs. 802.16e vs LTE

	UMTS	802.16e	LTE
Access method	CDMA	OFDMA, SOFDMA	SOFDMA
Frequency band	~ 2 GHz 2,5 ÷ 2,7 GHz	2,3 GHz 2,5 ÷ 2,7 GHz 3,5 GHz	900, 1800 ? ~ 2 GHz
Channel bandwidth	5 MHz	1,75 MHz ÷ 28 MHz	1,25 MHz ÷ 20 MHz
Data rates	2 Mbit/s (Rel 4) 14,4 Mbit/s (Rel 5) 5,8 Mbit/s (Rel 6)	63 Mbit/s (↓) 28 Mbit/s (↑)	100 Mbit/s (↓) 50 Mbit/s (↑)
Modes	FDD (TDD)	TDD, (FDD)	FDD, TDD ?
Handover	Yes	Yes	Yes
Power control	Yes	Yes	Yes
Support of QoS	Yes	Yes	Yes
AAS	No	Yes (MIMO, Beamforming)	Yes (MIMO, Beamforming)

Conclusions

- 4G → BWA
- Objectives of 4G
 - 100 Mbit/s for mobility
 - 1 Gbit/s for fixed/portable
- Candidates
 - Ultra Mobile Broadband (UMB) ...3GPP2
 - Long Term Evolution (LTE) ...3GPPP
 - Mobile WiMAX (802.16m) ...IEEE